



TS-G874-DS-1011

August 25, 2015

Interface Definition Document (IDD)

FOR THE

Adherent Cell Experiment Module

FOR THE

Multi-purpose Variable-g Platform (MVP)

Prepared by:

Techshot, Inc.

7200 Highway 150

Greenville, Indiana 47124

RECORD OF REVIEW AND APPROVAL

Approved By: _____

MVP Project Manager

e-mail: _____@techshot.com

Tel. 812-923-9591 ext. _____

Approved By: _____

MVP Project Scientist

e-mail: _____@techshot.com

Tel. 812-923-9591 ext. _____

Approved By: _____

MVP Integration Engineer

e-mail: _____@techshot.com

Tel. 812-923-9591 ext. _____

REVISION HISTORY

REV	DATE	PAGES AFFECTED	INSTRUCTIONS/REMARKS

TABLE OF CONTENTS

1.1 Scope..... 4

1.2 Adherent Cell Experiment Module general requirements..... 4

1.3 Identification of internal volume 5

1.4 On-orbit replaceable components within modules 7

1.5 Automation and manual planned activities/tasks 8

1.6 Environmental controls and monitoring 8

1.7 Camera images and lighting..... 9

1.8 Material selection for biocompatibility with cell cultures 9

1.9 Sterilization process for experiment modules and sub components 10

1.10 Concept of operations..... 10

1.1 Scope

Adherent cell research is a capability of Techshot's Multi-purpose Variable-g Platform (MVP). The MVP facility will reside in an EXPRESS Rack on the International Space Station (ISS) and can accommodate up to 12 experiment modules. There are two carousels that provide independent g-level control for up to 6 modules each.

The purpose of this IDD is to define the interfaces between the Adherent cell science and the MVP Adherent Cell Experiment Module developed by Techshot Inc.

1.2 Adherent Cell Experiment Module general requirements

1.2.1 The experiment module shall be designed to be compatible with the Techshot Multi-purpose Variable-g Platform (MVP). The experiment module shall fit within the generic form factor illustrated in Figure 1.

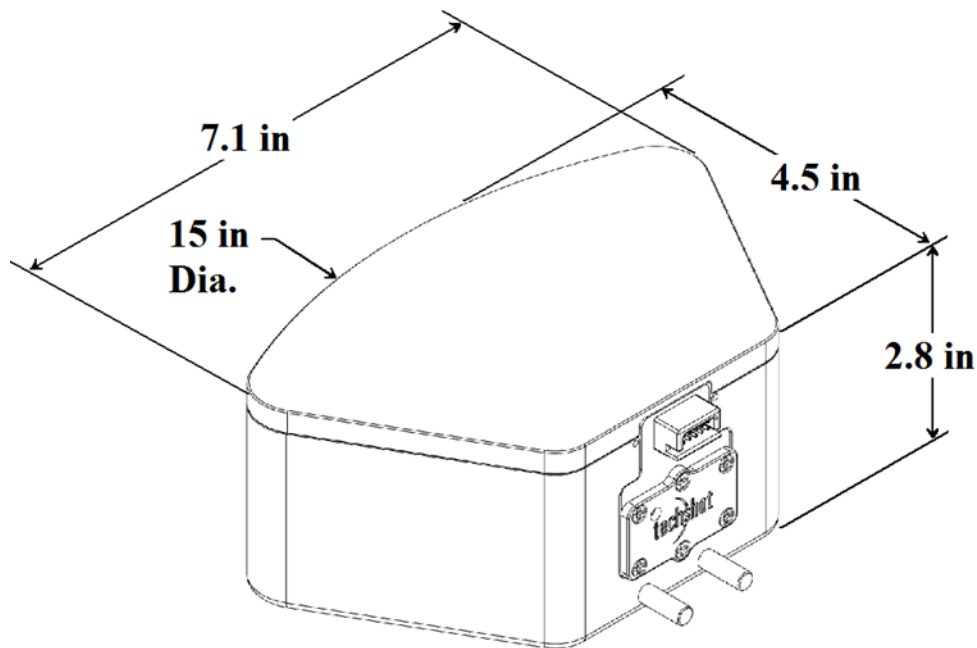

Figure 1 – Generic MVP experiment module dimensions

- 1.2.2 Researchers must identify the science-related contents and provide a toxicology report (or MSDS) for each. Experiment samples must be evaluated and approved by a JSC toxicologist.
- 1.2.3 The first level of containment is the bags and tubing that come in contact with the science-related contents.
- 1.2.4 The experiment module is sealed and provides two additional levels of containment. These seals are O-ring gaskets around the lid and electrical pass-through.
- 1.2.5 The experiment module lid shall be removable for loading and removing samples. The lid shall take no more than 5 minutes to remove and replace.

1.3 Identification of internal volume

- 1.3.1 The anatomy of the Adherent Cell Experiment module is shown in Figure 2. For this figure, the lid, tubing and bags have been removed.

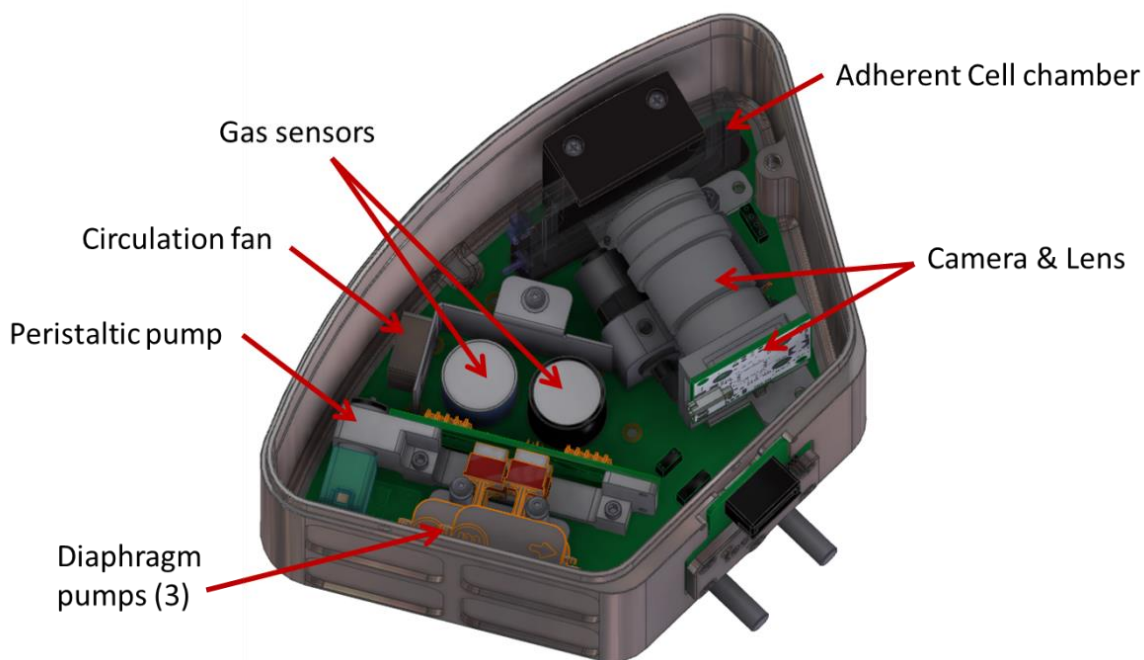

Figure 2 – Adherent Cell Experiment module. Not shown are the lid, tubing and bags.

1.3.2 A simplified schematic of the fluidics is shown in Figure 3. There are four supply bags (left) that have independent pumps to run fluid into the Adherent Cell Chamber. The cell chamber is a fixed volume so excess fluid is pushed into the waste bag (right). The camera will capture images from the center of the cell chamber.

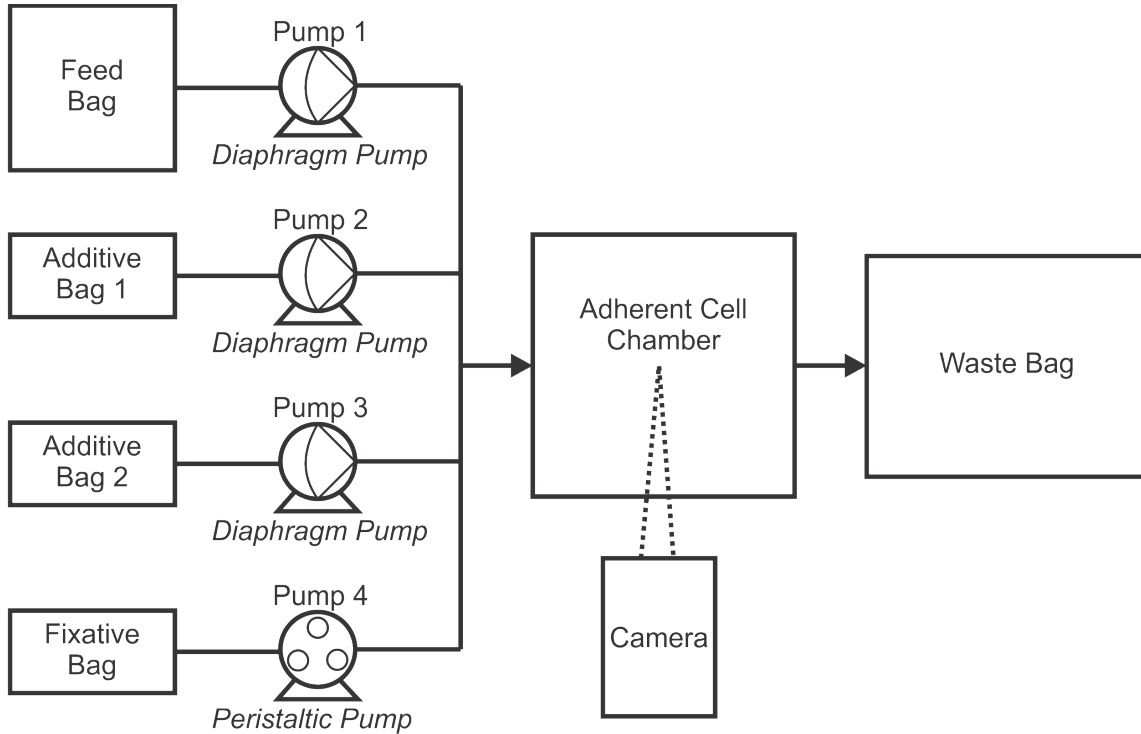

Figure 3 – Simplified schematic of the fluidics

1.3.3 The supply bags are as follows:

Feed Bag – Contains the medium used for cell nourishment

Additive Bags 1 and 2 – May be used to contain supplemental medium

Fixative Bag – May be used to fix/suspend the cells for a return trip

- 1.3.4 The Feed Bag shall hold up to 50mL of fluid.
 - 1.3.5 Additive Bags shall hold up to 5mL of fluid each (10mL total).
 - 1.3.6 The Fixative Bag shall hold up to 15mL of fluid.
 - 1.3.7 The Waste Bag(s) shall hold up to 75mL. This container is intended to be empty before starting a protocol.
 - 1.3.8 The volume of the Adherent Cell Chamber is 5mL. The surface area for adherent cell attachment is 16.1 cm² (2.5 in²).
 - 1.3.9 Feed and Additive pumps (Pumps 1-3) will have a maximum flow rate of 6mL/min. The flow rate accuracy of Pumps 1-3 are +/- 5%. The Experiment Protocol Timeline resolution for flow rate shall be 0.05mL/min and the start/stop time resolution is 0.1 second.
 - 1.3.10 The Fixative pump (Pump 4) will have a fixed flow rate between 0.4mL/min and 0.6mL/min. The Fixative pump may only be turned on and off in the Experiment Protocol Timeline. The start/stop time resolution is 0.1 second.
- 1.4 On-orbit replaceable components within modules
- 1.4.1 The experiment module is NOT serviceable by crew while on-orbit.

1.5 Automation and manual planned activities/tasks

- 1.5.1 Techshot's Payload Operations Control Center (POCC) will have a data link to the MVP facility and provide ground support during crew interactions. Techshot personnel will routinely monitor experiment progress, monitor hardware status and provide data/images to researchers. All data and images are recorded in MVP's on-board, non-volatile memory. Data is requested and downloaded to the Techshot POCC as permitted by bandwidth and communication to the ISS.
- 1.5.2 Automated tasks (associated with the experiment) are compiled into an experiment protocol timeline file. This file resides within the MVP CPU. The timeline is either initiated autonomously at a specified time or manually by the Techshot POCC.
- 1.5.3 Installation/removal of the Adherent Cell Experiment Module into the MVP facility is a manual process for the ISS crew that requires the MVP to be shut down and the front door opened. No tools are required to install/remove the experiment modules. The time required for experiment module installation (2 modules) is intended to take no more than 30 minutes of crew time.
- 1.5.4 Thermal control and g-level control are performed autonomously by the MVP facility. The setpoints are defined in the experiment protocol timeline. The timeline may contain multiple setpoint changes.
- 1.5.5 Fluidic control, Image capture, focal length and lighting intensity are performed autonomously by the MVP facility per the experiment protocol timeline.

1.6 Environmental controls and monitoring

- 1.6.1 The MVP facility shall control the internal environment to a set point between 14°C and 40°C \pm 2.5°C (57.2°F – 104°F). The thermal control loop is optimized for the temperature sensors within the experiment module. The experiment log will contain at least one reading per minute of the module's interior temperature.
- 1.6.2 The MVP facility will monitor CO₂ and O₂ levels within the experiment module. The experiment log will contain at least one reading per minute of CO₂ and O₂ readings.
- 1.6.3 Each MVP carousel shall have the capability to be controlled to a set point between 0g and 2g \pm 0.1g. Each MVP carousel g-level can be independently controlled from the other carousel. The carousel assemblies provide tachometer or encoder position as feedback. The experiment log will contain at least one reading per minute of g-levels.

1.7 Camera images and lighting

- 1.7.1 The experiment module shall be capable of collecting still images with a high-resolution camera and magnification lens.
- 1.7.2 The color camera shall be >10 megapixel resolution capability. The camera shall have an S-mount (M12) type, 20x magnification lens.
- 1.7.3 The camera mount shall be motorized such that the focal length can be adjusted throughout the depth of the optical cell volume.
- 1.7.4 Lighting is provided using LEDs at an optimal angle and wavelength for viewing the cell culture.
- 1.7.5 The experiment protocol timeline will contain controls for the camera focal length, lighting intensity and timing of image captures. The Techshot POCC will have the capability to override camera features from the ground.
- 1.7.6 The MVP facility shall provide at least 200GB of image storage. Note: This space is shared by all the experiment cameras in the MVP facility.
- 1.7.7 Image files are downloaded to the Techshot POCC as ISS communication bandwidth permits.

1.8 Material selection for biocompatibility with cell cultures

- 1.8.1 All membrane surfaces within the Adherent Cell Chamber will be tissue culture treated polystyrene with the remainder of the structure being a polycarbonate material.
- 1.8.2 Bags will be produced from Fluorinated Ethylene Propylene (FEP) or Polytetrafluoroethylene (PTFE).
- 1.8.3 Tubing will be Flexelene 75E and fittings will be polypropylene.

1.9 Sterilization process for experiment modules and sub components

- 1.9.1 Bags will be purchased sterile from supplier and the Adherent Cell Chamber will be supplied sterile as well.
- 1.9.2 Techshot will wipe down the outside of the Adherent Cell Culture Module and transfer it into a Class II type B2 Biological Safety Cabinet (BSC) or Class 100 Laminar Flow Hood (LFH) for further cleaning.
- 1.9.3 Techshot will wipe down all electronic components to prepare to assemble the Adherent Cell Culture Module. If immediate use is not intended, the module can be bagged for later use.
- 1.9.4 Techshot will prepare tubing assemblies with diaphragm pumps in place within the BSC or LFH and place in sealed Tyvek® pouch and process in Ethylene Oxide Sterilizer.
- 1.9.5 Techshot will sterilize all components in-house with monitoring strips for verification.
- 1.9.6 All components are now ready to be stored or assembled for use.

1.10 Concept of operations

The anticipated protocol will include two Adherent Cell Experiment Modules. One will be the “control group” held at 1-g and the other will be the “experimental group” that experiences micro-gravity. All other ambient conditions will be identical.

Techshot and researchers will create an Experiment Protocol Timeline that is used to configure the MVP facility for the desired events. The protocol is run several times on an MVP ground unit to validate the timed events and anticipated outcome. The validated timeline file is uploaded to the MVP facility prior to arrival of the experiment module on the ISS.

Cells and consumables are loaded (on the ground) into sterilized Adherent cell experiment modules and handed over to KSC Payload Integration personnel prior to launch. The Adherent Cell Experiment Modules will be transported to the ISS in thermally controlled stowage. After arrival, the crew will insert the experiment modules into the MVP facility and apply power.

During the experiment protocol, the MVP facility will maintain the experiment module’s environment and provide telemetry data and images to ground personnel at Techshot’s Payload Operations Control Center (POCC) in Greenville, IN.

A typical Adherent Cell Experiment protocol could be as follows:

- Feed Bag filled with DMEM with 10% Fetal Bovine Serum
- Additive Bag 1: DMEM with 10% Fetal Bovine Serum + induction factor 1
- Additive Bag 2: DMEM with 10% Fetal Bovine Serum + induction factor 2
- Fixative Bag: RNAlater
- Cell type: IPS from fibroblast

All sterile or clean components are shipped from Techshot to a KSC cleanroom to prepare for late load. Items are transferred into the BSC and individual bags are filled and system is primed. Cells are placed within Adherent Cell Chamber and allowed to adhere for 1 hour at 37C. Module is removed from incubator and placed in cold stowage (2-8C) aboard Dragon capsule late load for transit to station unpowered. After arriving at station, modules are placed within MVP, and powered and heated.

General feeding schedule will be to do 100% feeding every 3 days for 21 day experiment. Images will be sent daily to monitor % confluence and feedings at 50% and 80% will be substituted for additive bags 1 and 2 respectively.

At the conclusion of the growth and induction phase, cells will be fixed with RNAlater for analysis upon return within the Adherent Cell Culture Module.

Upon completion of this semi-autonomous protocol, the crew will remove the experiment module from the MVP facility. Depending on the experiment objectives, the crew will either discard the experiment module or prepare it for a return trip to Techshot.